

# 7150

Max. Lifting Capacity: **150** Metric Tons at **5** Meters  
 Max. Boom & Fixed Jib Length: **73.15 + 30.48** Meters

## Specifications

- Advanced winch system delivers a wide range of precisely controlled hoisting speeds, and the fastest hoisting in its class.
- Large main and auxiliary drums can be run simultaneously or independently at different speeds and in opposite directions, according to your needs.
- Two-speed propel system features high speed for travel, low for superior break-out force.
- Precise swing speed control allows for delicate inching operations.
- Direct fuel injection in an intercooled turbo engine delivers dependable performance with top fuel economy.

## General Dimensions

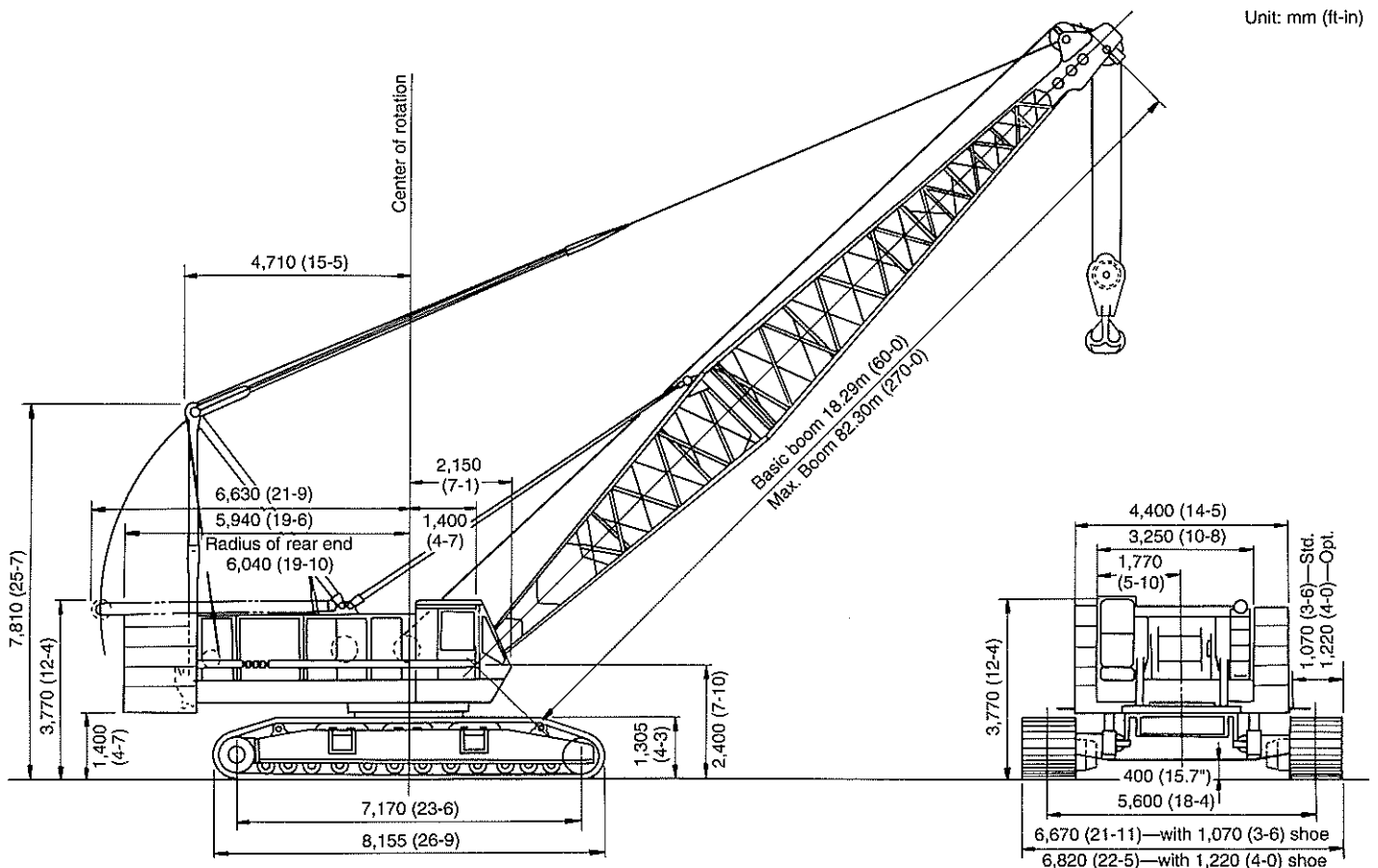

# Specifications

## Upper machinery



### Power plant

**Model** ..... Mitsubishi 6D22-TC  
**Type** ..... Water-cooled, direct fuel injection, intercooled turbo

**No. of cylinder** ..... 6  
**Bore and stroke** ..... 130mm x 140mm (5.1" x 5.5")  
**Displacement** ..... 11.1 liters  
**Rated power** ..... 294PS (216 kW) at 2,000 rpm (JIS D1005)

285 PS (210 kW) at 2,000 rpm (DIN 6270)  
 275 HP (205 kW) at 2,000 rpm (SAE J 816b)

**Max. torque** ..... 117 kg-m at 1,400 rpm (JIS D2005)

**Cooling system** ..... Liquid, recirculating bypass

**Starter** ..... 24 V, 5.5 kW

**Generator** ..... 24 V, 1.5 kW

**Cycles** ..... 4

**Radiator** ..... Vertical tube and fin type core, thermostatically controlled

**Air cleaner**.. Dry type with replaceable paper element

**Fuel tank capacity** ..... 400 liters (105 US gal)

**Batteries** ..... Two 12V, 200A-hr capacity batteries, series connected

**Fuel consumption** (at 1,400 rpm) ..... 154g/PS-h



### Hydraulic system

**Pumps:** All four variable displacement pumps are driven by heavy-duty pump drive. One of these pumps is used in the right

propel circuit and hook hoist circuit. Another is used in the left propel circuit and hook hoist circuit, and can accommodate an optional 3rd hoist circuit. The third is used in the boom hoist circuit, and the fourth variable displacement pump is used in the swing circuit. In addition, two gear pumps are used in the control system. One of these serves the clutch and brakes. The second pump can be used at the operator's discretion for a translifter, a cylinder for gantry lift, or a cylinder for boom foot pin or axle-pin coupling and decoupling.

**Control:** Fuel-flow hydraulic control system for infinitely variable pressure to front and rear drums, boom hoist brakes and clutches. Controls respond instantly to the touch, delivering smooth function operation.

**Pressure:** 280 kg/cm<sup>2</sup> (3,980 psi) maximum relief valve pressure

### Load hoist, boom hoist

**and propel system** ..... 280kg/cm<sup>2</sup> (4,000 psi)

**Swing system** ..... 230kg/cm<sup>2</sup> (3,290 psi)

**Control system** ..... 60kg/cm<sup>2</sup> (860 psi)

**Hoist drum service brake system** ..... 60kg/cm<sup>2</sup> (860 psi)

**Reservoir capacity:** 500 liters (132 US gal)

**Cooling:** Oil-to-air heat exchanger

**Filtration:** Fuel-flow and bypass type with replaceable paper element



### Boom hoisting system

Powered by a hydraulic axial piston motor through a planetary reducer.

**Brake:** A spring-set, hydraulically released multiple-disc brake is mounted on the boom hoist motor and operated through a counter-balance valve.

Safety pawls (external ratchet) are fitted for locking the drums.

**Drums:** Two in-line drums, each grooved for 20mm (0.79") wire rope.

**Line speed:** Single line on first drum layer

Hoisting (max.) ..... 25m/min (each)

Lowering (max.) ..... 25m/min (each)



### Load hoist system

Powered by two hydraulic axial piston motors, driven through a planetary reducer.

**Clutches:** Internally expanding band clutches.

**Brakes:** Externally contracting band brakes, each using positive and negative actuation.

**Drums:** (front and rear): 588mm (23") P.D. x 864mm (34") wide drums, each grooved for 26mm (1.02") wire rope. Rope capacity of 370m (1,213') working length and 490m (1,607") storage length.

**Line speed:** Single line on the first drum layer

Hoisting ..... 90/60/45/30m/min

Lowering ..... 90/60/45/30m/min



### Swing system

**Swing unit:** Powered by dual hydraulic axial piston motors driving spur gears through planetary reducers, the swing system provides

360° rotation.

**Swing speed** ..... 2.2/1.1 rpm

**Swing brakes:** A spring-set, hydraulically released multiple-disc brake is mounted on each swing motor.

**Swing circle:** Single-row ball bearing with an integral internally cut swing gear.

**House lock:** Four position pin-hole lock (manually engaged)



### Operator's cab

Totally enclosed, full-vision cab fitted with safety glass and a sliding front window. A fully adjustable, high-backed seat permits

operators to set their ideal working position. A signal horn, cigarette lighter, windshield wiper, inspection lamp socket and safety lock-lever are standard features.



### Controls

In front of the operator are foot pedals for front and rear drum brakes. At the operator's right are console-mounted adjustable

short levers for front and rear drum control, boom hoist control lever and positive/negative brake select switch for front and rear drum brakes. Beside the operator's seat on the right are two short levers for propel control. At the operator's left are: a console-mounted swing lever, an optional third drum control lever, and front and rear drum pawl control switches; switches for ignition, engine stop, low and high speed control for front drum, rear drum and propel; and creep speed control for hoist and propel. A swing brake switch and a signal horn button are on the swing lever.

**Gauges:** Fuel, engine water temperature, engine oil pressure, hour meter.

**Warning lamps:** Engine oil pressure, hydraulic oil pressure, battery charge, air cleaner and engine oil filter.

**Safety devices:** Hook over-hoist alarm and shut-off switch, boom over-hoist limit switch, boom angle indicator, signal horn, boom hoist and front and rear drum locks, swing lock, boom back stop, hook safety latch and optional load moment limiter (overload protection device) are provided.



**Gantry**

Folding type, fitted with sheave frame for boom hoist reeving. Lowers toward rear onto cab roof. Hydraulic lift is standard.

Full up, full down positions with linkage.

**Counterweight**

Five-piece stack, mounted behind the machinery compartment.

Total weight .....54,000kg (119,000 lb)



**Tools**

Tool set and accessories for routine machine maintenance are provided.

**Lower machinery**

**Carbody:** Steel-welded carbody with an integral seat designed for pin-connected axles.

**Crawler:** Crawler assemblies designed with a quick disconnect feature that allows complete individual removal from the axles. Crawler belt tension is maintained by hydraulic jack force on the track-adjusting bearing block.

**Crawler drive:** Independent hydraulic propel drive is built into each side frame, each with a hydraulic motor propelling a driving tumbler through a planetary gear box.

**Crawler brakes:** Spring-set, hydraulically released multiple-disc parking brakes are built into each propel drive.

**Steering mechanism:** A hydraulic propel system provides both skid steering (driving one track only) and counter-rotating steering (driving tracks in opposite directions).

**Track rollers:** 12 lower rollers and 2 upper rollers are fitted to each side frame, all permanently sealed and maintenance-free.

**Shoes:**

Number ..... 62 each side  
 Standard flat shoe width ..... 1,070mm (42")  
 (optional extra 1,220mm (48"))

**Max. travel speed:**

High range ..... 1.2km/h (0.75mph)  
 Low range ..... 0.6km/h (0.37mph)

**Max. gradeability:** 30%

**Carbody counterweight (optional)**

A two-piece carbody counterweight and an additional counterweight can be optionally specified for mounting on the carbody to increase lifting capacity.

**Carbody counterweight** ..... 20,000kg (44,100lb)

**Additional counterweight** ..... 8,300kg (18,300lb)

**Trans-Lifter (optional):** Trans-Lifter system allows quick and easy crawler side frame removal and trailer loading. 4 vertical cylinders lift the basic machine for self-loading onto trailer. 2 horizontal cylinders facilitate side frames for removal or replacement.

**Crane attachment**



**Boom:**

Welded lattice construction using tubular, high-tensile steel cords with pin connections between sections.

|                       |                       |
|-----------------------|-----------------------|
| Max. lifting capacity | 150,000kg (330,000lb) |
| Basic boom length     | 18.29m (60')          |
| Max. boom length      | 82.30m (270')         |



**Jib (optional):**

Welded lattice construction using tubular, high-tensile steel cords with pin connections between sections.

|   | Fixed jib     |
|---|---------------|
| Max. lifting capacity (kg)                          | 15,000        |
| Max. jib length (kg)                                | 30.48         |
| Max. total length (m)<br>(Boom length + jib length) | 73.15 + 30.48 |



**Hook blocks**

A range of hook blocks can be specified, each with a safety latch.

| Lifting capacity | 150 tons | 65 tons | 25 tons | 12 tons |
|------------------|----------|---------|---------|---------|
| No. of sheaves   | 7        | 3       | 1       | 0       |
| Weight (kg)      | 2,200    | 1,100   | 700     | 450     |

**Diameter of wire ropes**

**Standard:**

Hook hoist ..... 26mm (1.02")  
 Boom hoist (16-part line) ..... 20mm (0.79")  
 Boom pendants (4-part line) ..... 32mm (1.26")

**Optional:**

Jib hook hoist ..... 26mm (1.02")  
 Jib back stay pendants (2-part line) ..... 26mm (1.02")  
 Boom midpoint suspension ..... 22mm (0.08")

**Weight**

**Working weight:** Approx. 150,000kg (330,000lb) (including 18.29m (60ft) boom and 150ton hook block)

**Ground pressure:** 0.93kg/cm<sup>2</sup> with 1,070mm (42") shoes.

# Lifting Capacities

The following points should be kept in mind when interpreting the ratings given below.

- Operating radius is the horizontal distance from center of rotation to the hoist load line or tackle with load applied.
- Rated loads do not exceed 78% of tipping loads, and include weights of the load, hook blocks, slings and other lifting devices.
- Rated loads are for stationary and level cranes lifting a freely suspended load, and have been determined for ideal operating conditions. The user must limit or derate lifted loads to allow for adverse conditions (such as soft or uneven ground, out-of-level conditions, winds, side loads, pendulum action, jerking or sudden stopping of loads, inexperience of personnel, multiple machine lifts and traveling with a load.)
- Gantry must be in fully raised position for all operations.
- Crawlers must be leveled to within 1% on a firm supporting surface.
- When lifting over boom must be deducted 450kg.
- Midpoint suspensions are required for booms 64.01m (210') and longer.
- Boom lengths for jib mounting are 45.72m (150') to 73.15m (240').
- The boom should be erected over the front of the crawlers, not laterally.
- At radii and boom length where no ratings are shown on-plate operation is not intended or approved.
- Mast required when boom length is 60.96m (220') or longer.
- Boom insert and guy cables must be arranged as shown in the "Owner and Operator's Manual."
- Lifting capacities shown within the heavy lines are limited by the strength of the boom.
- Do not operate the machine with loads that exceed those shown.

## Working Ranges (with fixed jib)

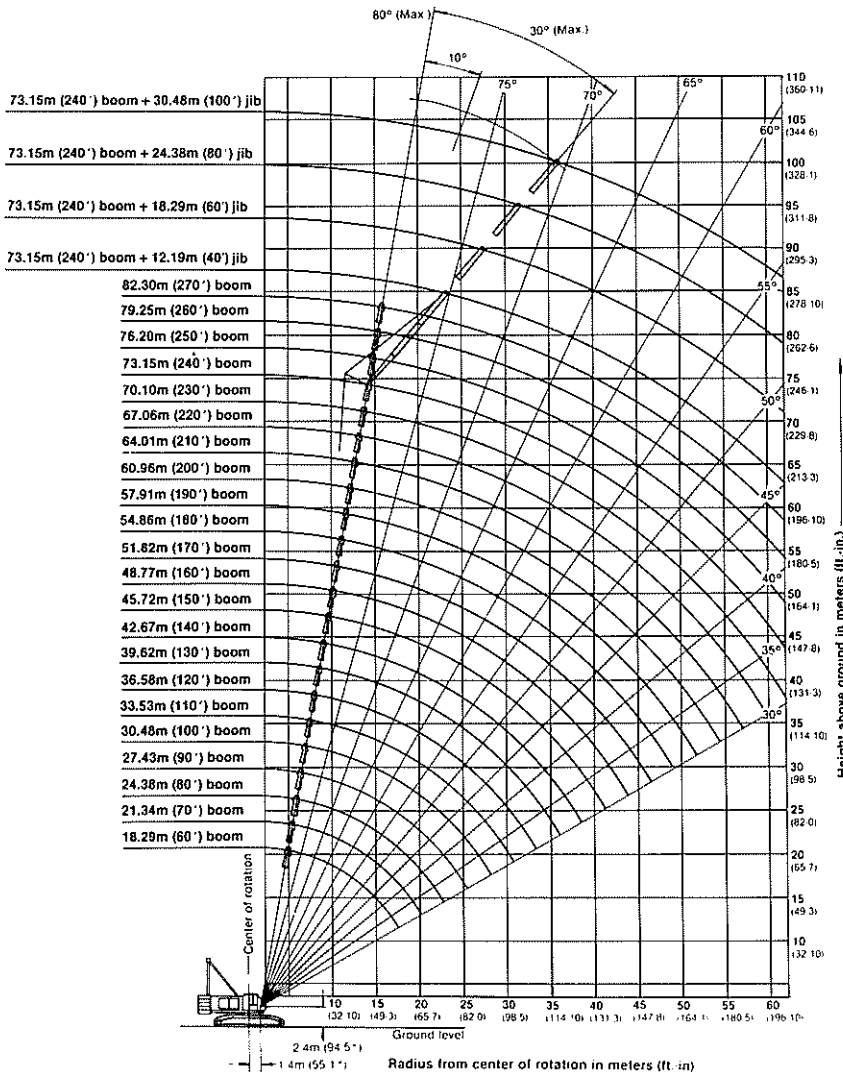

## Boom Component Chart

| Boom Length<br>m.(ft) | Boom arrangement         |
|-----------------------|--------------------------|
| 18.29 (60)            | Base-Tip                 |
| 21.34 (70)            | Base-A-Tip               |
| 24.38 (80)            | Base-B-Tip               |
| 27.43 (90)            | Base-C-Tip               |
| 30.48 (100)           | Base-A-C-Tip             |
| 33.53 (110)           | Base-B-C-Tip             |
| 36.58 (120)           | Base-A-B-C-Tip           |
| 39.62 (130)           | Base-A-C-C-Tip           |
| 42.67 (140)           | Base-B-C-C-Tip           |
| 45.72 (150)           | Base-C-C-C-Tip           |
| 48.77 (160)           | Base-A-C-C-C-Tip         |
| 51.82 (170)           | Base-B-C-C-C-Tip         |
| 54.86 (180)           | Base-A-B-C-C-C-Tip       |
| 57.91 (190)           | Base-A-A-B-C-C-C-Tip     |
| 60.96 (200)           | Base-A-C-C-C-D-Tip       |
| 64.01 (210)           | Base-A-A-C-C-C-D-Tip     |
| 67.06 (220)           | Base-A-A-C-C-D-D-Tip     |
| 70.10 (230)           | Base-A-B-C-C-D-D-Tip     |
| 73.15 (240)           | Base-A-B-C-C-A-D-D-Tip   |
| 76.20 (250)           | Base-A-A-C-C-C-D-D-Tip   |
| 79.25 (260)           | Base-A-B-C-C-C-D-D-Tip   |
| 82.30 (270)           | Base-A-B-C-C-A-C-D-D-Tip |

Base = 7.62m (25'), Tip = 10.7m (35')  
 Inserts: A = 3.05 m (10'), B = 6.10 m (20')  
 C = 9.14m (30'), D = 12.19 m (40')

## Jib Component Chart

| Jib Length<br>m.(ft) | Jib arrangement  |
|----------------------|------------------|
| 12.19 (40)           | Base-A-Tip       |
| 18.29 (60)           | Base-A-B-Tip     |
| 24.38 (80)           | Base-A-B-B-Tip   |
| 30.48 (100)          | Base-A-B-B-B-Tip |

Base = 4.57 m (15'), Tip = 4.57 m (15')  
 Inserts: A = 3.05m (10'), B = 6.10 m (20')

# Boom Lifting Capacities (Standard)



www.smithcranes.co.nz

## Rated Loads in Metric Tons for 360° Working Area (with standard counterweights)

Unit: metric ton

| Boom length<br>m (ft)<br>Operating<br>radius m (ft-in) | 18.29<br>(60) | 21.34<br>(70) | 24.38<br>(80) | 27.43<br>(90) | 30.48<br>(100) | 33.53<br>(110) | 36.58<br>(120) | 39.62<br>(130) | 42.67<br>(140) | 45.72<br>(150) | 48.77<br>(160) | Boom length<br>m (ft)<br>Operating<br>radius m (ft-in) |
|--|---------------|---------------|---------------|---------------|----------------|----------------|----------------|----------------|----------------|----------------|----------------|--|
| 5 (16-5)   | 150.0         |               |               |               |                |                |                |                |                |                |                | 5 (16-5)   |
| 6 (19-8)   | 140.0         | 128.1         | 116.8         |               |                |                |                |                |                |                |                | 6 (19-8)   |
| 7 (23-0)   | 123.6         | 121.7         | 111.5         | 102.5         | 94.4           |                |                |                |                |                |                | 7 (23-0)   |
| 8 (26-3)   | 99.1          | 98.8          | 98.7          | 96.2          | 90.7           | 83.8           | 77.8           |                |                |                |                | 8 (26-3)   |
| 9 (29-6)   | 82.5          | 82.3          | 82.2          | 82.0          | 81.8           | 78.8           | 75.2           | 69.6           |                |                |                | 9 (29-6)   |
| 10 (32-10)   | 70.5          | 70.3          | 70.2          | 70.1          | 69.9           | 69.8           | 69.2           | 66.5           | 62.3           | 57.8           |                | 10 (32-10)   |
| 12 (39-4)  | 54.6          | 54.3          | 54.2          | 54.0          | 53.8           | 53.7           | 53.5           | 53.3           | 53.2           | 52.2           | 49.6           | 12 (39-4)  |
| 14 (45-11)   | 44.5          | 44.2          | 44.0          | 43.9          | 43.6           | 43.5           | 43.2           | 43.1           | 42.9           | 42.7           | 42.6           | 14 (45-11)   |
| 16 (52-6)  | 37.5          | 37.1          | 37.0          | 36.8          | 36.5           | 36.4           | 36.1           | 35.9           | 35.8           | 35.6           | 35.5           | 16 (52-6)  |
| 18 (59-0)  |               | 32.0          | 31.8          | 31.6          | 31.3           | 31.1           | 30.8           | 30.7           | 30.6           | 30.4           | 30.2           | 18 (59-0)  |
| 20 (65-7)  |               |               | 27.8          | 27.6          | 27.3           | 27.1           | 26.8           | 26.7           | 26.5           | 26.3           | 26.2           | 20 (65-7)  |
| 22 (72-2)  |               |               | 24.7          | 24.4          | 24.2           | 24.0           | 23.7           | 23.5           | 23.4           | 23.1           | 23.0           | 22 (72-2)  |
| 24 (78-9)  |               |               |               | 21.9          | 21.6           | 21.4           | 21.1           | 20.9           | 20.8           | 20.6           | 20.4           | 24 (78-9)  |
| 26 (85-4)  |               |               |               |               | 19.5           | 19.3           | 19.0           | 18.8           | 18.7           | 18.4           | 18.2           | 26 (85-4)  |
| 28 (91-10)   |               |               |               |               |                | 17.5           | 17.2           | 17.0           | 16.9           | 16.6           | 16.4           | 28 (91-10)   |
| 30 (98-5)  |               |               |               |               |                | 16.1           | 15.7           | 15.5           | 15.4           | 15.1           | 14.9           | 30 (98-5)  |
| 32 (105-0)   |               |               |               |               |                |                | 14.4           | 14.2           | 14.0           | 13.8           | 13.6           | 32 (105-0)   |
| 34 (111-7)   |               |               |               |               |                |                |                | 13.1           | 12.9           | 12.7           | 12.5           | 34 (111-7)   |
| 36 (118-1)   |               |               |               |               |                |                |                |                | 11.9           | 11.7           | 11.5           | 36 (118-1)   |
| 38 (124-8)   |               |               |               |               |                |                |                |                | 11.1           | 10.8           | 10.6           | 38 (124-8)   |
| 40 (131-3)   |               |               |               |               |                |                |                |                |                | 10.1           | 9.8            | 40 (131-3)   |
| 42 (137-10)  |               |               |               |               |                |                |                |                |                |                | 9.1            | 42 (137-10)  |

Unit: metric ton

| Boom length<br>m (ft)<br>Operating<br>radius m (ft-in) | 51.82<br>(170) | 54.86<br>(180) | 57.91<br>(190) | 60.96<br>(200) | 64.01<br>(210) | 67.06<br>(220) | 70.10<br>(230) | 73.15<br>(240) | 76.20<br>(250) | 79.25<br>(260) | 82.30<br>(270) | Boom length<br>m (ft)<br>Operating<br>radius m (ft-in) |
|--|----------------|----------------|----------------|----------------|----------------|----------------|----------------|----------------|----------------|----------------|----------------|--|
| 12 (39-4)  | 46.9           | 43.5           | 40.0           |                |                |                |                |                |                |                |                | 12 (39-4)  |
| 14 (45-11)   | 41.8           | 40.3           | 38.1           | 37.0           | 36.2           | 33.5           | 30.3           |                |                |                |                | 14 (45-11)   |
| 16 (52-6)  | 35.2           | 35.1           | 33.8           | 35.6           | 35.2           | 32.7           | 29.6           | 27.1           | 25.0           | 22.8           | 20.3           | 16 (52-6)  |
| 18 (59-1)  | 30.0           | 29.8           | 29.6           | 30.3           | 30.1           | 30.1           | 28.8           | 26.4           | 24.4           | 22.1           | 19.7           | 18 (59-1)  |
| 20 (65-7)  | 25.9           | 25.7           | 25.5           | 26.2           | 25.9           | 25.9           | 25.9           | 25.7           | 23.8           | 21.6           | 19.2           | 20 (65-7)  |
| 22 (72-2)  | 22.8           | 22.5           | 22.3           | 22.9           | 22.6           | 22.7           | 22.6           | 22.4           | 22.3           | 21.0           | 18.6           | 22 (72-2)  |
| 24 (78-9)  | 20.2           | 19.9           | 19.7           | 20.2           | 20.0           | 20.0           | 20.0           | 19.7           | 19.6           | 19.4           | 18.0           | 24 (78-9)  |
| 26 (85-4)  | 18.0           | 17.7           | 17.6           | 18.0           | 17.8           | 17.8           | 17.7           | 17.5           | 17.4           | 17.2           | 16.7           | 26 (85-4)  |
| 28 (91-10)   | 16.2           | 15.9           | 15.8           | 16.2           | 15.9           | 15.9           | 15.9           | 15.6           | 15.5           | 15.3           | 15.2           | 28 (91-10)   |
| 30 (98-5)  | 14.7           | 14.4           | 14.3           | 14.6           | 14.3           | 14.3           | 14.3           | 14.0           | 13.9           | 13.7           | 13.6           | 30 (98-5)  |
| 32 (105-0)   | 13.4           | 13.1           | 12.9           | 13.2           | 13.0           | 13.0           | 12.9           | 12.6           | 12.5           | 12.3           | 12.3           | 32 (105-0)   |
| 34 (111-7)   | 12.2           | 11.9           | 11.8           | 12.0           | 11.8           | 11.8           | 11.7           | 11.4           | 11.3           | 11.1           | 11.1           | 34 (111-7)   |
| 36 (118-1)   | 11.2           | 10.9           | 10.8           | 11.0           | 10.7           | 10.7           | 10.7           | 10.4           | 10.3           | 10.1           | 10.0           | 36 (118-1)   |
| 38 (124-8)   | 10.3           | 10.1           | 9.9            | 10.1           | 9.8            | 9.8            | 9.8            | 9.5            | 9.3            | 9.1            | 9.1            | 38 (124-8)   |
| 40 (131-3)   | 9.6            | 9.3            | 9.1            | 9.3            | 9.0            | 9.0            | 8.9            | 8.6            | 8.5            | 8.3            | 8.2            | 40 (131-3)   |
| 42 (137-10)  | 8.9            | 8.6            | 8.4            | 8.5            | 8.2            | 8.2            | 8.2            | 7.9            | 7.8            | 7.6            | 7.5            | 42 (137-10)  |
| 44 (144-4)   | 8.2            | 7.9            | 7.7            | 7.9            | 7.6            | 7.6            | 7.5            | 7.2            | 7.1            | 6.9            | 6.8            | 44 (144-4)   |
| 46 (150-11)  | 7.7            | 7.4            | 7.2            | 7.3            | 7.0            | 7.0            | 6.9            | 6.6            | 6.5            | 6.2            | 6.1            | 46 (150-11)  |
| 48 (157-6)   |                | 6.9            | 6.6            | 6.7            | 6.4            | 6.4            | 6.4            | 6.0            | 5.9            | 5.6            | 5.4            | 48 (157-6)   |
| 50 (164-1)   |                |                | 6.2            | 6.2            | 5.9            | 5.9            | 5.9            | 5.5            | 5.3            | 5.0            | 4.9            | 50 (164-1)   |
| 52 (170-7)   |                |                |                | 5.8            | 5.4            | 5.4            | 5.3            | 4.9            | 4.7            | 4.5            | 4.3            | 52 (170-7)   |
| 54 (177-0)   |                |                |                | 5.4            | 5.0            | 5.0            | 4.8            | 4.4            | 4.2            | 4.0            | 3.8            | 54 (177-0)   |
| 56 (183-9)   |                |                |                |                | 4.5            | 4.5            | 4.4            | 4.0            | 3.8            | 3.5            | 3.4            | 56 (183-9)   |
| 58 (190-3)   |                |                |                |                |                | 4.1            | 4.0            | 3.6            | 3.4            | 3.1            | 2.9            | 58 (190-3)   |
| 60 (196-10)  |                |                |                |                |                |                | 3.6            | 3.2            | 3.0            | 2.7            | 2.5            | 60 (196-10)  |
| 62 (203-5)   |                |                |                |                |                |                | 3.2            | 2.8            | 2.6            | 2.4            | 2.2            | 62 (203-5)   |

# Boom Lifting Capacities

(with carbody counterw  
an additional counterw



## Rated Loads in Metric Tons for 360° Working Area (with carbody counterweights and an additional counterweight)

www.smithcranes.co.nz

Unit: metric ton

| Boom length<br>m (ft)<br>Operating<br>radius m (ft-in) | 18.29<br>(60) | 21.34<br>(70) | 24.38<br>(80) | 27.43<br>(90) | 30.48<br>(100) | 33.53<br>(110) | 36.58<br>(120) | 39.62<br>(130) | 42.67<br>(140) | 45.72<br>(150) | 48.77<br>(160) | Boom length<br>m (ft)<br>Operating<br>radius m (ft-in) |
|--|---------------|---------------|---------------|---------------|----------------|----------------|----------------|----------------|----------------|----------------|----------------|--|
| 5 (16-5)   | 150.0         |               |               |               |                |                |                |                |                |                |                | 5 (16-5)   |
| 6 (19-8)   | 140.0         | 128.1         | 116.8         |               |                |                |                |                |                |                |                | 6 (19-8)   |
| 7 (23-0)   | 123.6         | 121.7         | 111.5         | 102.5         | 94.4           |                |                |                |                |                |                | 7 (23-0)   |
| 8 (26-3)   | 104.8         | 104.6         | 102.3         | 96.2          | 90.7           | 83.8           | 77.8           |                |                |                |                | 8 (26-3)   |
| 9 (29-6)   | 90.0          | 90.4          | 89.8          | 87.1          | 82.7           | 79.5           | 75.2           | 69.6           |                |                |                | 9 (29-6)   |
| 10 (32-10)   | 78.4          | 79.3          | 79.1          | 78.5          | 75.6           | 72.7           | 69.4           | 66.5           | 62.3           | 57.8           |                | 10 (32-10)   |
| 12 (39-4)  | 61.1          | 62.9          | 63.4          | 63.3          | 62.6           | 61.8           | 59.3           | 56.8           | 54.7           | 52.2           | 50.2           | 12 (39-4)  |
| 14 (45-11)   | 48.5          | 51.2          | 52.3          | 52.6          | 52.3           | 51.8           | 51.1           | 49.5           | 47.7           | 45.5           | 43.8           | 14 (45-11)   |
| 16 (52-6)  | 38.4          | 42.1          | 43.9          | 44.4          | 44.2           | 44.0           | 43.7           | 43.3           | 42.1           | 40.2           | 38.7           | 16 (52-6)  |
| 18 (59-0)  |               | 34.6          | 37.1          | 38.2          | 37.9           | 37.7           | 37.5           | 37.4           | 37.1           | 36.0           | 34.7           | 18 (59-0)  |
| 20 (65-7)  |               |               | 31.3          | 32.9          | 33.1           | 32.9           | 32.7           | 32.5           | 32.3           | 32.2           | 31.2           | 20 (65-7)  |
| 22 (72-2)  |               |               | 26.0          | 28.3          | 29.3           | 29.1           | 28.9           | 28.7           | 28.5           | 28.4           | 28.1           | 22 (72-2)  |
| 24 (78-9)  |               |               |               | 24.1          | 25.5           | 26.1           | 25.8           | 25.7           | 25.4           | 25.3           | 25.0           | 24 (78-9)  |
| 26 (85-4)  |               |               |               |               | 22.1           | 23.2           | 23.3           | 23.1           | 22.9           | 22.7           | 22.5           | 26 (85-4)  |
| 28 (91-10)   |               |               |               |               |                | 20.3           | 21.0           | 21.0           | 20.8           | 20.6           | 20.3           | 28 (91-10)   |
| 30 (98-5)  |               |               |               |               |                | 17.6           | 18.6           | 19.1           | 18.9           | 18.8           | 18.5           | 30 (98-5)  |
| 32 (105-0)   |               |               |               |               |                |                | 16.3           | 17.1           | 17.4           | 17.2           | 16.9           | 32 (105-0)   |
| 34 (111-7)   |               |               |               |               |                |                |                | 15.1           | 15.7           | 15.9           | 15.6           | 34 (111-7)   |
| 36 (118-1)   |               |               |               |               |                |                |                |                | 14.0           | 14.4           | 14.4           | 36 (118-1)   |
| 38 (124-8)   |               |               |               |               |                |                |                |                | 12.3           | 12.9           | 13.1           | 38 (124-8)   |
| 40 (131-3)   |               |               |               |               |                |                |                |                |                | 11.5           | 11.8           | 40 (131-3)   |
| 42 (137-10)  |               |               |               |               |                |                |                |                |                |                | 10.5           | 42 (137-10)  |

Unit: metric ton

| Boom length<br>m (ft)<br>Operating<br>radius m (ft-in) | 51.82<br>(170) | 54.86<br>(180) | 57.91<br>(190) | 60.96<br>(200) | 64.01<br>(210) | 67.06<br>(220) | 70.10<br>(230) | 73.15<br>(240) | 76.20<br>(250) | 79.25<br>(260) | 82.30<br>(270) | Boom length<br>m (ft)<br>Operating<br>radius m (ft-in) |
|--|----------------|----------------|----------------|----------------|----------------|----------------|----------------|----------------|----------------|----------------|----------------|--|
| 12 (39-4)  | 46.9           | 43.5           | 40.0           |                |                |                |                |                |                |                |                | 12 (39-4)  |
| 14 (45-11)   | 41.8           | 40.3           | 38.1           | 37.0           | 36.2           | 33.5           | 30.3           |                |                |                |                | 14 (45-11)   |
| 16 (52-6)  | 36.9           | 35.6           | 33.8           | 35.6           | 35.2           | 32.7           | 29.6           | 27.1           | 25.0           | 22.8           | 20.3           | 16 (52-6)  |
| 18 (59-1)  | 33.0           | 31.8           | 30.2           | 32.9           | 33.7           | 31.3           | 28.8           | 26.4           | 24.4           | 22.1           | 19.7           | 18 (59-1)  |
| 20 (65-7)  | 29.8           | 28.7           | 27.2           | 29.5           | 31.8           | 30.5           | 27.6           | 25.7           | 23.8           | 21.6           | 19.2           | 20 (65-7)  |
| 22 (72-2)  | 27.1           | 26.0           | 24.7           | 26.6           | 27.9           | 27.9           | 26.8           | 24.6           | 22.7           | 21.0           | 18.6           | 22 (72-2)  |
| 24 (78-9)  | 24.7           | 23.8           | 22.5           | 24.2           | 24.7           | 24.7           | 24.7           | 23.9           | 21.4           | 19.6           | 18.0           | 24 (78-9)  |
| 26 (85-4)  | 22.3           | 21.8           | 20.7           | 22.0           | 22.1           | 22.1           | 22.1           | 21.8           | 20.1           | 18.2           | 16.9           | 26 (85-4)  |
| 28 (91-10)   | 20.2           | 19.9           | 19.0           | 20.1           | 19.9           | 19.9           | 19.8           | 19.6           | 18.8           | 17.0           | 15.7           | 28 (91-10)   |
| 30 (98-5)  | 18.4           | 18.1           | 17.5           | 18.3           | 18.0           | 18.0           | 18.0           | 17.7           | 17.6           | 15.8           | 14.6           | 30 (98-5)  |
| 32 (105-0)   | 16.8           | 16.5           | 16.1           | 16.6           | 16.4           | 16.4           | 16.3           | 16.1           | 15.9           | 14.8           | 13.5           | 32 (105-0)   |
| 34 (111-7)   | 15.4           | 15.1           | 14.9           | 15.2           | 15.0           | 15.0           | 14.9           | 14.6           | 14.5           | 13.8           | 12.5           | 34 (111-7)   |
| 36 (118-1)   | 14.2           | 13.9           | 13.8           | 14.0           | 13.7           | 13.7           | 13.7           | 13.4           | 13.3           | 12.7           | 11.5           | 36 (118-1)   |
| 38 (124-8)   | 13.2           | 12.9           | 12.7           | 12.9           | 12.6           | 12.6           | 12.6           | 12.3           | 12.2           | 11.6           | 10.4           | 38 (124-8)   |
| 40 (131-3)   | 12.0           | 11.9           | 11.7           | 11.9           | 11.6           | 11.6           | 11.6           | 11.3           | 11.2           | 10.6           | 9.7            | 40 (131-3)   |
| 42 (137-10)  | 10.8           | 10.8           | 10.7           | 11.1           | 10.8           | 10.8           | 10.7           | 10.4           | 10.3           | 9.9            | 9.0            | 42 (137-10)  |
| 44 (144-4)   | 9.7            | 9.8            | 9.7            | 10.3           | 10.0           | 10.0           | 9.9            | 9.6            | 9.5            | 9.3            | 8.5            | 44 (144-4)   |
| 46 (150-11)  | 8.6            | 8.8            | 8.8            | 9.6            | 9.3            | 9.3            | 9.2            | 8.9            | 8.8            | 8.6            | 7.8            | 46 (150-11)  |
| 48 (157-6)   |                | 7.8            | 7.9            | 8.9            | 8.6            | 8.6            | 8.5            | 8.2            | 8.1            | 7.9            | 7.4            | 48 (157-6)   |
| 50 (164-1)   |                |                | 7.0            | 8.3            | 8.0            | 8.0            | 7.9            | 7.6            | 7.5            | 7.3            | 6.8            | 50 (164-1)   |
| 52 (170-7)   |                |                |                | 7.8            | 7.5            | 7.5            | 7.4            | 7.1            | 7.0            | 6.8            | 6.3            | 52 (170-7)   |
| 54 (177-0)   |                |                |                | 7.3            | 7.0            | 7.0            | 6.9            | 6.6            | 6.4            | 6.2            | 5.8            | 54 (177-0)   |
| 56 (183-9)   |                |                |                |                | 6.5            | 6.5            | 6.4            | 6.1            | 5.9            | 5.6            | 5.4            | 56 (183-9)   |
| 58 (190-3)   |                |                |                |                |                | 6.1            | 6.0            | 5.6            | 5.4            | 5.1            | 4.9            | 58 (190-3)   |
| 60 (196-10)  |                |                |                |                |                |                | 5.5            | 5.2            | 5.0            | 4.7            | 4.5            | 60 (196-10)  |
| 62 (203-5)   |                |                |                |                |                |                |                | 5.1            | 4.7            | 4.5            | 4.1            | 62 (203-5)   |
| 64 (210-0)   |                |                |                |                |                |                |                |                | 4.3            | 4.1            | 3.7            | 64 (210-0)   |

# Fixed Jib Lifting Capacities



www.smithcranes.co.nz

Unit: metric ton

## Jib Rated Loads in Metric Tons for 360° Working Area

| Operating radius<br>m (ft-in) | 45.72m (150') boom |      |                  |     |                  |     |                   |     | Operating radius<br>m (ft-in) |
|-------------------------------|--------------------|------|------------------|-----|------------------|-----|-------------------|-----|-------------------------------|
|                               | 12.19m (40') jib   |      | 18.29m (60') jib |     | 24.38m (80') jib |     | 30.48m (100') jib |     |                               |
|                               | Offset angle       |      |                  |     |                  |     |                   |     |                               |
|                               | 10°                | 30°  | 10°              | 30° | 10°              | 30° | 10°               | 30° |                               |
| 14 (45-11)                    | 15.0               |      |                  |     |                  |     |                   |     | 14 (45-11)                    |
| 16 (52-6)                     | 15.0               |      |                  |     |                  |     |                   |     | 16 (52-6)                     |
| 18 (59-0)                     | 15.0               | 13.0 | 12.0             |     |                  |     |                   |     | 18 (59-0)                     |
| 20 (65-7)                     | 15.0               | 13.0 | 12.0             |     | 8.0              |     |                   |     | 20 (65-7)                     |
| 22 (72-2)                     | 15.0               | 13.0 | 12.0             | 8.0 | 8.0              |     | 4.0               |     | 22 (72-2)                     |
| 24 (78-9)                     | 15.0               | 13.0 | 12.0             | 8.0 | 8.0              |     | 4.0               |     | 24 (78-9)                     |
| 26 (85-4)                     | 15.0               | 13.0 | 12.0             | 8.0 | 7.8              | 6.0 | 4.0               |     | 26 (85-4)                     |
| 28 (91-10)                    | 15.0               | 12.6 | 12.0             | 8.0 | 7.6              | 6.0 | 4.0               |     | 28 (91-10)                    |
| 30 (98-5)                     | 15.0               | 12.3 | 12.0             | 8.0 | 7.4              | 6.0 | 4.0               |     | 30 (98-5)                     |
| 34 (111-7)                    | 12.7               | 11.5 | 11.5             | 8.0 | 7.1              | 6.0 | 4.0               | 3.0 | 34 (111-7)                    |
| 38 (124-8)                    | 10.8               | 10.8 | 10.6             | 7.6 | 6.7              | 5.7 | 3.7               | 3.0 | 38 (124-8)                    |
| 40 (131-3)                    | 10.1               | 10.1 | 10.1             | 7.4 | 6.5              | 5.5 | 3.6               | 3.0 | 40 (131-3)                    |

Unit: metric ton

| Operating radius<br>m (ft-in) | 57.91m (190') boom |      |                  |     |                  |     |                   |     | Operating radius<br>m (ft-in) |
|-------------------------------|--------------------|------|------------------|-----|------------------|-----|-------------------|-----|-------------------------------|
|                               | 12.19m (40') jib   |      | 18.29m (60') jib |     | 24.38m (80') jib |     | 30.48m (100') jib |     |                               |
|                               | Offset angle       |      |                  |     |                  |     |                   |     |                               |
|                               | 10°                | 30°  | 10°              | 30° | 10°              | 30° | 10°               | 30° |                               |
| 14 (45-11)                    |                    |      |                  |     |                  |     |                   |     | 14 (45-11)                    |
| 16 (52-6)                     | 15.0               |      |                  |     |                  |     |                   |     | 16 (52-6)                     |
| 18 (59-0)                     | 15.0               |      |                  |     |                  |     |                   |     | 18 (59-0)                     |
| 20 (65-7)                     | 15.0               | 13.0 | 12.0             |     |                  |     |                   |     | 20 (65-7)                     |
| 22 (72-2)                     | 15.0               | 13.0 | 12.0             |     | 8.0              |     |                   |     | 22 (72-2)                     |
| 24 (78-9)                     | 15.0               | 13.0 | 12.0             | 8.0 | 8.0              |     | 4.0               |     | 24 (78-9)                     |
| 26 (85-4)                     | 15.0               | 13.0 | 12.0             | 8.0 | 8.0              |     | 4.0               |     | 26 (85-4)                     |
| 28 (91-10)                    | 15.0               | 13.0 | 12.0             | 8.0 | 8.0              | 6.0 | 4.0               |     | 28 (91-10)                    |
| 30 (98-5)                     | 14.3               | 13.0 | 12.0             | 8.0 | 8.0              | 6.0 | 4.0               |     | 30 (98-5)                     |
| 34 (111-7)                    | 11.8               | 11.8 | 11.8             | 8.0 | 7.6              | 6.0 | 4.0               | 3.0 | 34 (111-7)                    |
| 38 (124-8)                    | 9.9                | 9.9  | 9.9              | 8.0 | 7.2              | 6.0 | 4.0               | 3.0 | 38 (124-8)                    |
| 42 (137-10)                   | 8.4                | 8.4  | 8.4              | 7.7 | 6.8              | 5.7 | 3.9               | 3.0 | 42 (137-10)                   |
| 46 (150-11)                   | 7.2                | 7.2  | 7.2              | 7.2 | 6.4              | 5.4 | 3.6               | 2.9 | 46 (150-11)                   |
| 50 (164-1)                    | 6.2                | 6.2  | 6.2              | 6.2 | 6.0              | 5.1 | 3.3               | 2.8 | 50 (164-1)                    |

Unit: metric ton

| Operating radius<br>m (ft-in) | 73.15m (240') boom |      |                  |     |                  |     |                   |     | Operating radius<br>m (ft-in) |
|-------------------------------|--------------------|------|------------------|-----|------------------|-----|-------------------|-----|-------------------------------|
|                               | 12.19m (40') jib   |      | 18.29m (60') jib |     | 24.38m (80') jib |     | 30.48m (100') jib |     |                               |
|                               | Offset angle       |      |                  |     |                  |     |                   |     |                               |
|                               | 10°                | 30°  | 10°              | 30° | 10°              | 30° | 10°               | 30° |                               |
| 18 (59-0)                     | 15.0               |      |                  |     |                  |     |                   |     | 18 (59-0)                     |
| 20 (65-7)                     | 15.0               |      |                  |     |                  |     |                   |     | 20 (65-7)                     |
| 22 (72-2)                     | 15.0               | 13.0 | 12.0             |     |                  |     |                   |     | 22 (72-2)                     |
| 24 (78-9)                     | 15.0               | 12.7 | 12.0             |     | 8.0              |     |                   |     | 24 (78-9)                     |
| 26 (85-4)                     | 15.0               | 12.4 | 12.0             |     | 8.0              |     | 4.0               |     | 26 (85-4)                     |
| 28 (91-10)                    | 15.0               | 12.1 | 12.0             | 8.0 | 8.0              |     | 4.0               |     | 28 (91-10)                    |
| 30 (98-5)                     | 14.0               | 11.8 | 12.0             | 8.0 | 8.0              |     | 4.0               |     | 30 (98-5)                     |
| 34 (111-7)                    | 11.4               | 10.4 | 11.4             | 8.0 | 8.0              | 6.0 | 4.0               |     | 34 (111-7)                    |
| 38 (124-8)                    | 9.5                | 9.5  | 9.5              | 8.0 | 7.7              | 6.0 | 4.0               | 3.0 | 38 (124-8)                    |
| 42 (137-10)                   | 7.9                | 7.9  | 7.9              | 7.8 | 7.4              | 6.0 | 4.0               | 3.0 | 42 (137-10)                   |
| 46 (150-11)                   | 6.6                | 6.6  | 6.6              | 6.6 | 6.6              | 5.6 | 4.0               | 3.0 | 46 (150-11)                   |
| 50 (164-1)                    | 5.5                | 5.5  | 5.5              | 5.5 | 5.5              | 5.1 | 3.7               | 3.0 | 50 (164-1)                    |
| 54 (177-0)                    | 4.4                | 4.4  | 4.4              | 4.4 | 4.4              | 4.4 | 3.5               | 2.8 | 54 (177-0)                    |
| 58 (190-3)                    | 3.6                | 3.6  | 3.6              | 3.6 | 3.6              | 3.6 | 3.2               | 2.7 | 58 (190-3)                    |
| 62 (203-5)                    | 2.8                | 2.8  | 2.8              | 2.8 | 2.8              | 2.8 | 2.8               | 2.5 | 62 (203-5)                    |

Note: This chart presents rated jib loads for three possible boom lengths. Data for boom lengths from 150 to 240 feet at 10-foot intervals is available upon request.

# Luffing Tower Lifting Capacities

## Working Ranges

### • Luffing Tower Length: 56.69m

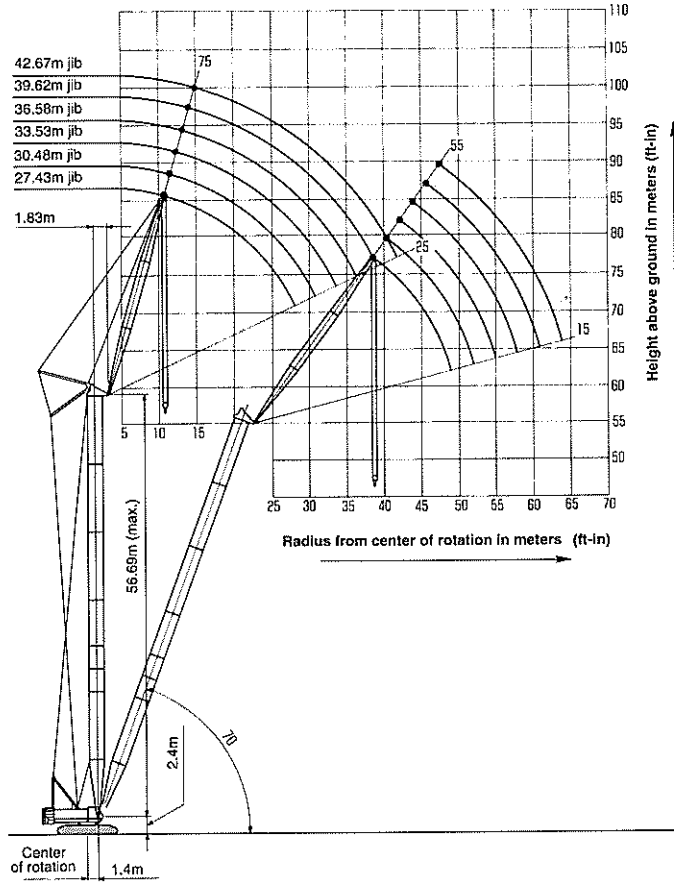

### • Luffing Tower Length: 50.09m

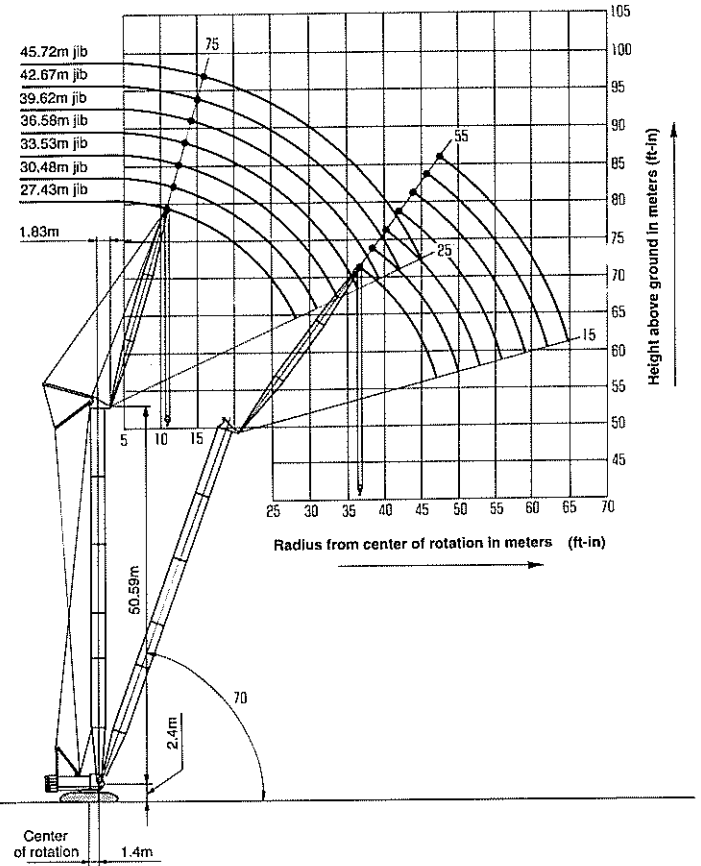

### • Luffing Tower Length: 44.99m

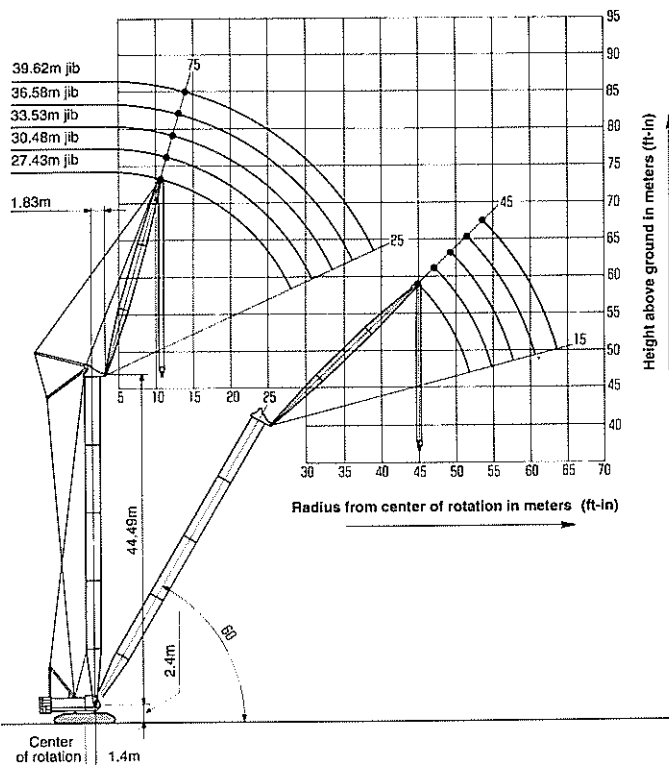

### • Luffing Tower Length: 38.40m

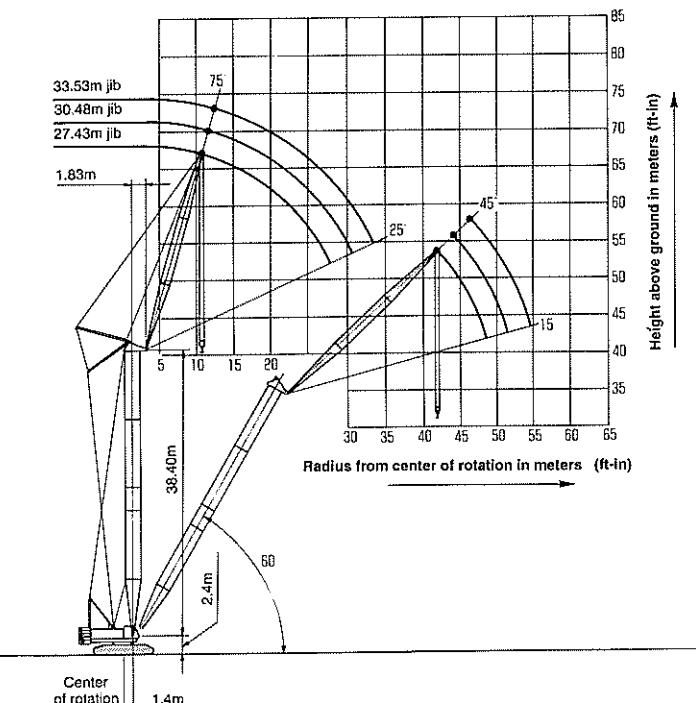



# Luffing Tower Lifting Capacities

## Rated Loads in Metric Tons for 360° Working Area

| Tower length m(ft.) | 35.35(116)  |            |             |            |             |           |
|---------------------|-------------|------------|-------------|------------|-------------|-----------|
|                     | 27.43(90)   |            |             | 30.48(100) |             |           |
| Jib length m(ft.)   | Tower angle |            | Tower angle |            | Tower angle |           |
| Operating radius    | 90°         | 75°        | 60°         | 90°        | 75°         | 60°       |
| 10.0(32-10)         | 10.8m 20.0  |            |             | 11.6m 20.0 |             |           |
| 12.0(39-4)          | 20.0        |            |             | 20.0       |             |           |
| 14.0(45-11)         | 15.8m 20.0  |            |             | 15.8m 20.0 |             |           |
| 16.0(52-6)          | 19.6        |            |             | 19.6       |             |           |
| 18.0(59-1)          | 17.8        |            |             | 17.8       |             |           |
| 20.0(65-7)          | 16.2        |            |             | 16.2       |             |           |
| 22.0(72-2)          | 14.8        |            |             | 14.8       |             |           |
| 24.0(78-9)          | 13.5        |            |             | 13.5       |             |           |
| 26.0(85-4)          | 12.2        | 26.4m 12.0 |             | 12.2       |             |           |
| 28.0(91-10)         | 11.0        | 11.0       |             | 11.0       | 11.0        |           |
| 30.0(98-5)          | 28.1m 10.8  | 9.9        |             | 9.9        | 9.9         |           |
| 32.0(105-0)         |             | 9.1        |             | 30.9m 9.5  | 9.1         |           |
| 34.0(111-7)         |             | 8.4        |             |            | 8.4         |           |
| 36.0(118-1)         |             | 7.7        |             |            | 7.7         |           |
| 38.0(124-8)         |             | 7.1        |             |            | 7.1         |           |
| 40.0(131-3)         |             | 38.8m 6.9  | 40.4m 6.4   |            | 6.5         |           |
| 42.0(137-10)        |             |            | 6.0         |            | 47.1m 6.1   | 42.6m 5.9 |
| 44.0(144-4)         |             |            | 5.6         |            |             | 5.6       |
| 46.0(150-11)        |             |            | 5.1         |            |             | 5.1       |
| 48.0(157-6)         |             |            | 47.2m 4.9   |            |             | 4.7       |
| 50.0(164-1)         |             |            |             |            |             | 4.4       |
| 52.0(170-7)         |             |            |             |            |             | 50.1m 4.5 |
| 54.0(177-0)         |             |            |             |            |             |           |
| 56.0(183-9)         |             |            |             |            |             |           |

## Configuration of luffing tower and jib

| Jib length m(ft.) | 27.43 (90) | 30.48 (100) | 33.53 (110) | 36.58 (120) | 39.62 (130) | 42.67 (140) | 45.72 (150) | Tower angle | Steel plate |
|-------------------|------------|-------------|-------------|-------------|-------------|-------------|-------------|-------------|-------------|
| 35.35(116)        | ○          | ○           | ×           | ×           | ×           | ×           | ×           | 60°~90°     | ×           |
| 38.40(126)        | ○          | ○           | ○           | ×           | ×           | ×           | ×           | 60°~90°     | ×           |
| 41.44(136)        | ○          | ○           | ○           | ○           | ×           | ×           | ×           | 60°~90°     | ×           |
| 44.49(146)        | ○          | ○           | ○           | ○           | ○           | ×           | ×           | 60°~90°     | ×           |
| 47.54(156)        | ○          | ○           | ○           | ○           | ○           | ○           | ×           | 70°~90°     | ×           |
| 50.59(166)        | ○*         | ○           | ○           | ○           | ○           | ○           | ○           | 70°~90°     | ×           |
| 53.64(176)        | ○*         | ○*          | ○           | ○           | ○           | ○           | ○           | 70°~90°     | ○           |
| 56.69(186)        | ○*         | ○*          | ○           | ○           | ○           | ○           | ×           | 70°~90°     | ○           |
| Hook              | 65ton      | 65ton       | 25ton       | 25ton       | 25ton       | 25ton       | 25ton       |             |             |

○ : Available    × : Not available

○\* : Should be equipped with weight (400kg) for jib tip to tip of upper jib.

### Notes:

- Rated loads are within 78% of minimum tipping load with the machine standing on firm level ground, and include the weight of lifting devices such as hook blocks, slings etc.
- With 27.43m(90') or 30.48m(100') jibs, a 65ton hook should be used.
- For the self-erection or dismantling of a 53.64m(176') or 56.69m(186') tower, be sure to support the machine on the special self-erection steel plate.
- When using a 27.43m(90') jib and a tower height exceeding 50.59m(166'), or with a 30.48m(100') jib and a tower height exceeding 53.64m(176'), attach a jib tip weight(400kg) to the top of the jib.

## Luffing tower attachment

### Luffing tower & jib:

|   |  |
|---|--|
| Max. lifting capacity                             | 20,000kg (44,000lb)  |
| Basic total length<br>(Tower length + jib length) | 35.35m (116') + 27.43m (90')                               |
| Max. total length<br>(Tower length + jib length)  | 56.69 (186') + 42.67 (140')<br>53.64 (176') + 45.72 (150') |

### Hook block weight and max. hoisting loads (metric ton)

| Hook Capacity | Max. hoisting loads |        | Hook weight |
|---------------|---------------------|--------|-------------|
|               | 1-line              | 2-line |             |
| 65 ton        | 11 ton              | 20 ton | 1.1 ton     |
| 25 ton        | 11 ton              | 20 ton | 0.7 ton     |

## Tower Component Chart

| Tower length meters(ft) | Tower arrangement       |
|-------------------------|-------------------------|
| 35.35(116)              | Base-C'-C-C-Cap         |
| 38.40(126)              | Base-C'-A-C-C-Cap       |
| 41.44(136)              | Base-C'-B-C-C-Cap       |
| 44.49(146)              | Base-C'-C-C-C-Cap       |
| 47.54(156)              | Base-C'-A-C-C-C-Cap     |
| 50.59(166)              | Base-C'-B-C-C-C-Cap     |
| 53.64(176)              | Base-C'-A-B-C-C-C-Cap   |
| 56.69(186)              | Base-C'-A-A-B-C-C-C-Cap |

Base = 7.62 m(25'), Cap = 0.31 m(1')

Inserts: B = 6.10 m(20'), C = 9.14 m(30')

A = 3.05 m(10'), C' = 9.14 m(30')

Note: C' 9.14 m(30') boom is for luffing tower use only.

## Jib Component Chart

| Jib length meters(ft) | Jib arrangement  | NO. of rollers for insert lines |
|-----------------------|------------------|---------------------------------|
| 27.43(90)             | Base-C-Tip       | -                               |
| 30.48(100)            | Base-A-C-Tip     | -                               |
| 33.53(110)            | Base-B-C-Tip     | 1                               |
| 36.58(120)            | Base-C-C-Tip     | 1                               |
| 39.62(130)            | BaseA-C-C-Tip    | 1                               |
| 42.67(140)            | BaseB-C-C-Tip    | 2                               |
| 45.72(150)            | Base-A-B-C-C-Tip | 2                               |

Base = 9.14m(30'), Tip = 9.14m(30')

Inserts: A = 3.05m(10'), B = 6.10m(20')

C = 9.14m(30')

- During operation, the luffing tower can be angled according to the following table.

| Tower height           | Permissible tower angle |
|------------------------|-------------------------|
| More than 47.54m(156') | 70° - 90°               |
| Less than 44.49m(146') | 60° - 90°               |

- Maximum rated load values assume that 26mm diameter nafx cable is used.

## Diameter of wire ropes

|                                  |  |
|----------------------------------|--|
| Main hook hoist                  | 26mm (1.02")                               |
| Tower jib hoist                  | 26mm (1.02")                               |
| Tower hoist                      | 20mm (1.26")                               |
| Tower jib pendants (2-part line) | 36mm (1.02") - Tower<br>22mm (0.08") - Jib |

## Weight

**Working weight:** Approx. 168,000kg (370,400lb)  
(including 56.69m boom and 42.67m jib)

**Ground pressure:** 1.03kg/cm<sup>2</sup>



# Clamshell

## 10.5 Metric Ton (23,100 lb) Rated Load 24.37m Maximum Boom

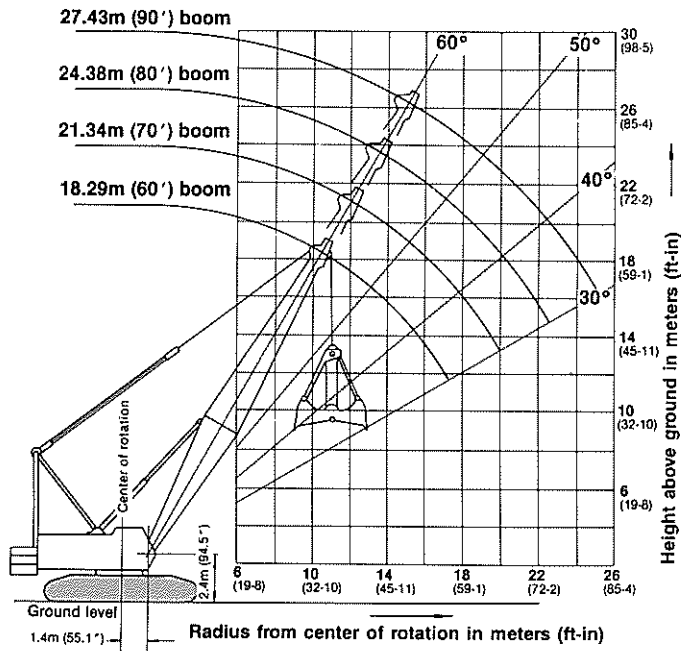

### Rated Loads in kg (standard)

| Boom length<br>m (ft)<br>Operating<br>radius m(ft-in) | 18.29<br>(60)<br>boom | 21.34<br>(70)<br>boom | 24.38<br>(80)<br>boom | 27.43<br>(90)<br>boom |
|---|-----------------------|-----------------------|-----------------------|-----------------------|
| 10.0 (32-10)  | 10,500                |                       |                       |                       |
| 12.0 (39-4)   | 10,500                | 10,500                |                       |                       |
| 14.0 (45-11)  | 10,500                | 10,500                | 10,500                |                       |
| 16.0 (52-6)   | 10,500                | 10,500                | 10,500                | 10,500                |
| 18.0 (59-1)   |                       | 10,500                | 10,500                | 10,500                |
| 20.0 (65-7)   |                       |                       | 10,500                | 10,500                |
| 22.0 (72-2)   |                       |                       |                       | 10,500                |
| 24.0 (78-9)   |                       |                       |                       | 10,500                |

Note: Table shows loads using standard 26 mm wire and standard drums.

### Rated Loads in kg (optional)

| Boom length<br>m (ft)<br>Operating<br>radius m(ft-in) | 18.29<br>(60)<br>boom | 21.34<br>(70)<br>boom | 24.38<br>(80)<br>boom | 27.43<br>(90)<br>boom |
|---|-----------------------|-----------------------|-----------------------|-----------------------|
| 10.0 (32-10)  | 12,500                |                       |                       |                       |
| 12.0 (39-4)   | 12,500                | 12,500                |                       |                       |
| 14.0 (45-11)  | 12,500                | 12,500                | 12,500                |                       |
| 16.0 (52-6)   | 12,500                | 12,500                | 12,500                | 12,500                |
| 18.0 (59-1)   |                       | 12,500                | 12,500                | 12,500                |
| 20.0 (65-7)   |                       |                       | 12,500                | 12,500                |
| 22.0 (72-2)   |                       |                       |                       | 12,500                |
| 24.0 (78-9)   |                       |                       |                       | 12,500                |

Note: Table shows loads using optional 28 mm wire and optional drums.

Above ratings are combined weights of bucket and material. Clamshell ratings shown also apply to grapple and all other material handling buckets except dragline. For clamshell operations, the weight of bucket is considered a part of the load and the total weight of bucket plus contents must not exceed the corresponding rating shown.

- Limit on clamshell rating ..... 10,500 kg (23,100 lb)
- Limit on clamshell rating (using 28 mm dia. wire rope— opt.)....  
..... 12,500 kg (27,600 lb)
- Maximum allowable bucket ..... 3.0 m<sup>3</sup> (3.9 cu yd)
- Maximum allowable bucket weight ..... 6,000 kg (13,200lb)

#### Note:

To select the bucket size best suited for your application, use the following formula: refer to the above charts to obtain clamshell capacity in kg. Clamshell capacity = (cubic meter capacity of bucket) x (weight of material per cubic meter) + ( weight of specific clamshell bucket).

# Upgraded Lifting Capacity

The following graphs show how hoisting capacity can be increased, using the 20 metric ton carbody counterweight and additional 8.3 metric ton counterweight

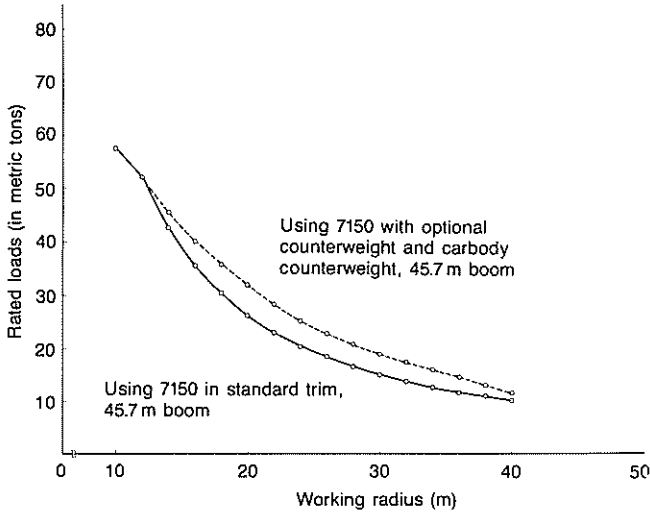
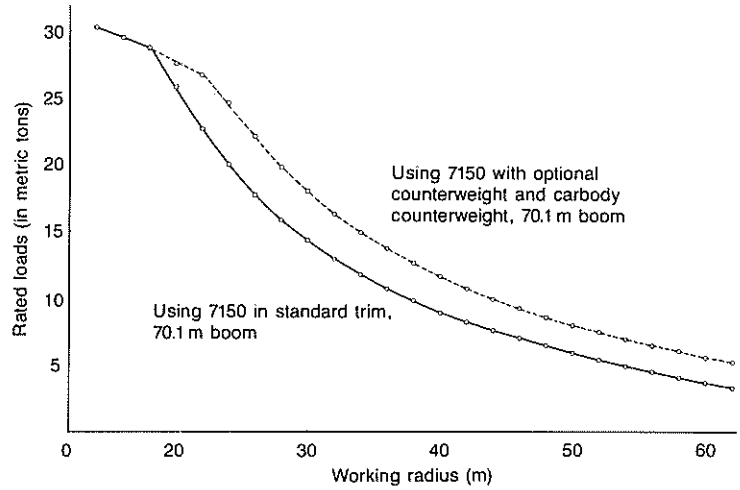
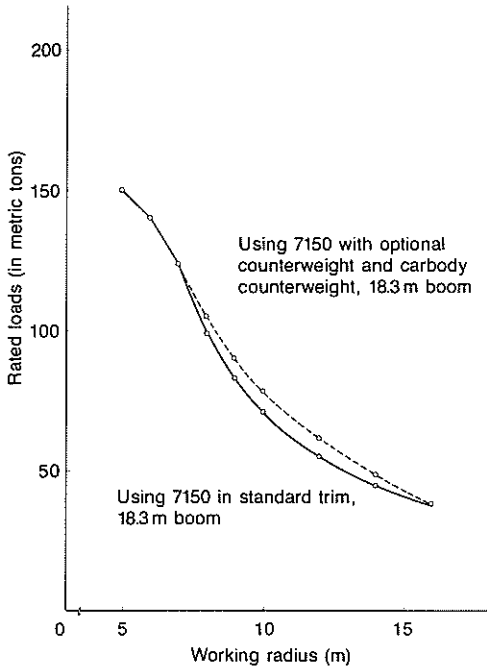

Address inquiries to:

NOTE: Due to our policy of continual product improvement, all designs and specifications are subject to change without advance notice.



**KOBE STEEL, LTD.**

ENGINEERING & MACHINERY DIVISION  
Construction Machinery & Compressor Group

27-8, Jingumae 6-chome, Shibuya-ku, TOKYO, 150 Japan  
Tel: (03)3797-7021/ Fax: (03) 3797-7072

This catalog is printed on recycled paper.  
940303TF Printed in Japan